

McIntosh
MC 100

OWNER'S MANUAL

THE McINTOSH MC 100 SOLID STATE POWER AMPLIFIER



\$1.25

Your MC 100 Solid State Power Amplifier will give you many years of pleasant and satisfactory performance. If you have any questions concerning the operation or maintenance of this instrument, please contact:

CUSTOMER SERVICE

McIntosh Laboratory Inc.
2 Chambers Street
Binghamton, New York 13903
Phone: 607-723-3512

**Take Advantage of 3 years
of FREE Factory Service . . .
Fill in the Application NOW.**

CONTENTS

GUARANTEE	1
INSTALLATION	2
HOW TO CONNECT	2,3
ADJUSTMENTS	2
PERFORMANCE LIMITS	4
PERFORMANCE CHARTS	5
TECHNICAL DESCRIPTION	6
BLOCK DIAGRAM	7

GUARANTEE

McIntosh Laboratory Incorporated guarantees this instrument to be capable of performance as advertised. We also guarantee the mechanical and electrical workmanship and components to be free of defects for a period of 90 days from date of purchase. If such defects occur, McIntosh Laboratory or

one of its authorized agencies will repair the defect at no cost to the purchaser. This guarantee does not extend to components damaged by improper use nor does it extend to transportation to and from the factory or service agency.

THREE YEAR FACTORY SERVICE CONTRACT

An application for a FREE THREE YEAR FACTORY SERVICE CONTRACT is included with this manual. The terms of the contract are:

For Three Years from date of purchase —

1. McIntosh will provide all parts, materials and labor needed to return the measured performance of the instrument to the original performance limits free of any charge. The SERVICE CONTRACT does not cover any shipping costs to and from the authorized service agency or the factory.
2. Any McIntosh authorized service agency will repair all McIntosh instruments at normal service rates. To receive the free service under the terms of the SERVICE CONTRACT, the SERVICE CONTRACT CERTIFICATE must accompany the instrument when taken to the service agency.
3. Always have service done by a McIntosh authorized service agency. If the instrument is modified or damaged as a result of unauthorized repair the SERVICE CONTRACT will be cancelled.

4. The SERVICE CONTRACT is issued to you as the original purchaser. To protect you from misrepresentation this contract cannot be transferred to a second owner.
5. The SERVICE CONTRACT is given to purchasers who live in the 50 United States or Canada only.
6. For your protection McIntosh selects its dealers carefully. Only one dealer in ten qualifies for a McIntosh franchise. To receive the SERVICE CONTRACT your purchase must be made from a McIntosh franchised dealer.
7. Your completely filled in application for a SERVICE CONTRACT must be postmarked within 30 days of the date of purchase of the instrument.
8. To receive the SERVICE CONTRACT all information on the application must be filled in. The SERVICE CONTRACT will be issued when the completely filled in application is received at McIntosh Laboratory Incorporated in Binghamton, New York. If the application is not received at McIntosh Laboratory, only the service offered under the 90-day guarantee will apply.

Installation

Adequate ventilation extends the trouble-free life of electronic instruments. It is generally found that each 10° centigrade (18° F) rise in temperature reduces the life of electrical insulation by one half. Adequate ventilation is an inexpensive and effective means of preventing insulation breakdown that results from unnecessarily high operating temperatures. The direct benefit of adequate ventilation is longer, trouble-free life.

The suggested minimum space for mounting the MC 100 is 16 inches long X 8 inches wide X 10½ inches high. Always allow for air flow by either ventilation holes or space next to the bottom of the amplifier and a means for the warm air to escape at the top.

It is recommended that the MC 100 be mounted in a normal or horizontal position. However with adequate ventilation, the amplifier can be mounted in any position except upside down. If the amplifier is to be installed on a vertical surface it is recommended that the autoformer be on the down side. This position permits greater air flow around the transistors and component parts extending the trouble-free life of the amplifier.

How to Connect

INPUT

The input sensitivity of the MC 100 is 0.5 volt for 100 watts output. The input impedance is 200,000 ohms. There is a GAIN control in the input circuit to permit the use of input voltages up to 30 volts. The input jack marked 0.5 VOLT INPUT is located below the GAIN control. Plug the shielded lead from the program source in the INPUT jack.

OUTPUT

Speakers are connected at the barrier strips marked OUTPUT on the sloped panel of the amplifier. Use lamp cord, bell wire, or wire with similar type of insulation to connect the speakers to the amplifier. For the normally short distances of under 50 feet between the amplifier and speaker, #18 wire or larger can be used. For distances over 50 feet between the amplifier and speaker use larger wire.

The loudspeaker impedance is usually identified on the loudspeaker. Connect one of the leads from the

loudspeaker to the screw marked COM on the OUTPUT barrier strip. Connect the other lead from the loudspeaker to the screw marked with the number corresponding to the speaker impedance on the OUTPUT barrier strip.

The only adverse effect on the operation of a McIntosh amplifier when it is improperly matched is a reduction in the amount of distortion-free power available to the loudspeaker. Close impedance matching is desirable for maximum distortion-free power.

SPEAKER CONNECTIONS

Use this table to determine proper speaker connection:

If the speaker impedance is between:	Connect the speaker leads between COM and:
3.2 to 6.5 ohms	4 ohms
6.5 to 13 ohms	8 ohms
13 to 26 ohms	16 ohms

For 25 volt line operation connect one of the leads to the screw marked COM on the OUTPUT barrier strip. The other lead is connected to the screw marked 8 on the OUTPUT barrier strip.

AC POWER

The MC 100 operates on 105 volt to 130 volt, 50 to 60 Hz. The amplifier will be turned on and off if its power cord is plugged in one of the auxiliary AC power outlets on the program source.

FUSE

The MC 100 is fused with a slo-blo type fuse rated at 2.5 amperes. For maximum protection always replace with fuses of the same rating, never larger. The AC power outlet on the MC 100 is not fused.

Adjustments

For maximum flexibility set the amplifier gain control as follows: turn the volume control on the program source equipment (i.e. tape recorder, tuner, preamplifier, etc.) to the 12 o'clock position. Turn the gain control on the MC 100 until the loudness of the sound from the speaker is just a little louder than you normally like to listen. The volume control on the program source equipment now has the most convenient amount of loudness change in either direction from the 12 o'clock position.

How to Connect

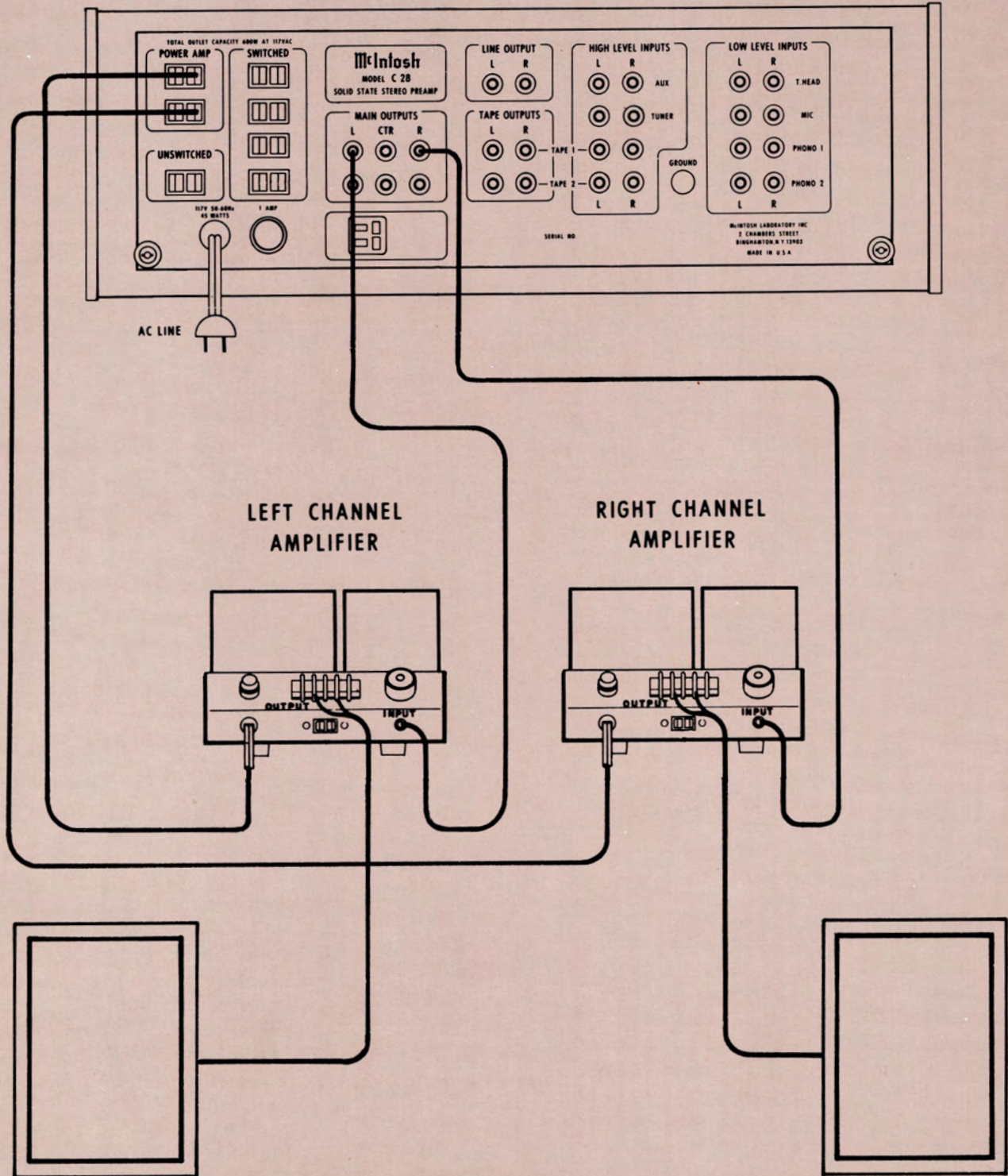

Performance Limits

Performance Limits are the maximum deviation from perfection permitted for a McIntosh instrument. We promise you that the MC 100 you buy must be capable of performance at or exceeding these limits or you get your money back. McIntosh is the only manufacturer that makes this guarantee.

POWER OUTPUT:

100 RMS watts continuous into 4, 8, or 16 ohms.

HARMONIC DISTORTION:

Will not exceed 0.2% at any power level to 100 watts output from 20 Hz to 20,000 Hz. Typical performance is less than 0.1% at rated power. Distortion decreases as output power is reduced.

INTERMODULATION DISTORTION:

Will not exceed 0.2% if instantaneous peak power is 200 watts or less for any combination of frequencies 20 Hz to 20,000 Hz.

FREQUENCY RESPONSE:

20 Hz to 30,000 Hz ± 0 -0.1 dB at rated power.
10 Hz to 50,000 Hz ± 0 -0.5 db at rated power.
7 Hz to 100,000 Hz ± 0 -3.0 db at one-half rated power.

NOISE AND HUM:

90 db or more below rated output.

OUTPUT IMPEDANCE

4, 8, and 16 ohms.

OUTPUT VOLTAGE:

25 volts from 8 ohm tap.

DAMPING FACTOR:

29 at 4 ohms output.
16 at 8 ohms output.
12 at 16 ohms output.

INPUT IMPEDANCE:

200,000 ohms.

INPUT SENSITIVITY:

0.5 volt. Level control provided for higher input voltage.

POWER REQUIREMENTS:

117 volts 50/60 Hz, 40 watts at zero signal output.
230 watts at rated output.

SEMICONDUCTOR COMPLEMENT:

16 silicon transistors.
10 silicon rectifiers and diodes.

MECHANICAL INFORMATION:

SIZE:

6½ inches high, 9¼ inches wide, 14¾ inches deep.

CHASSIS:

Chrome and black.

WEIGHT:

32 pounds net, 38 pounds in shipping carton.

SPECIAL FEATURES

The amplifier is completely stable when connected to any loudspeaker system or even to any reactive loads. The MC 100 has special circuits to prevent damage by short circuit or open circuit of the output loads, or by any amount of output impedance mismatch.

Thermal cutouts are mounted on the output transistor heat sinks to provide protection in the event of inadequate ventilation.

Performance Charts

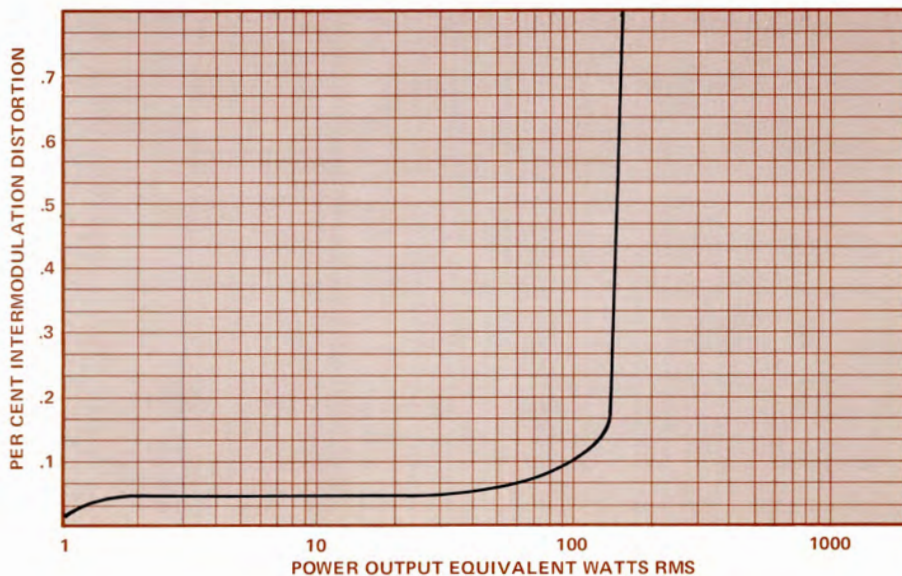
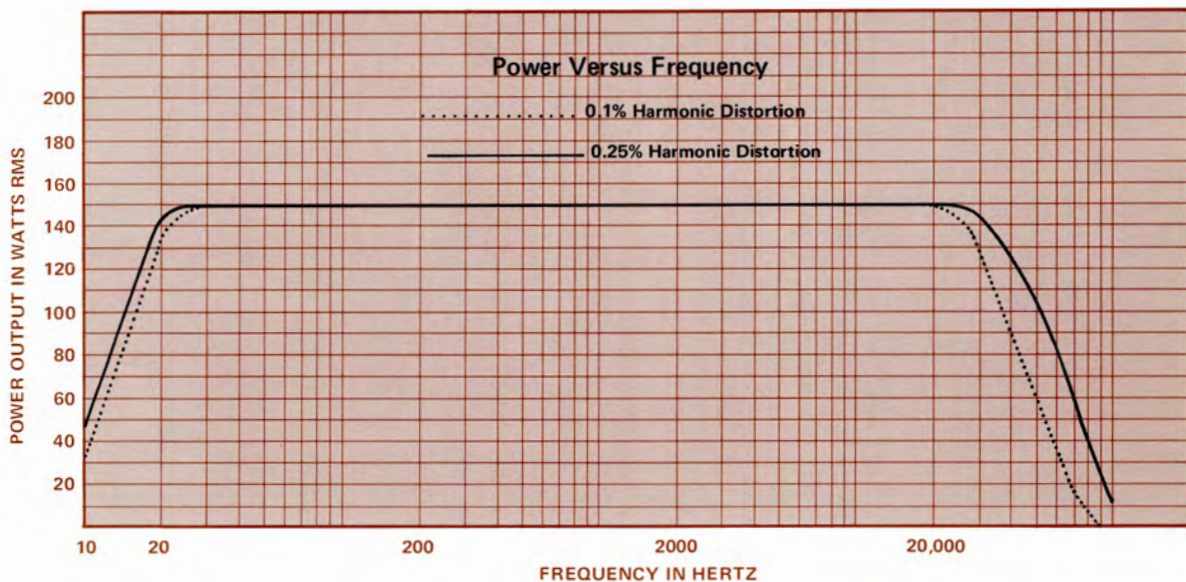
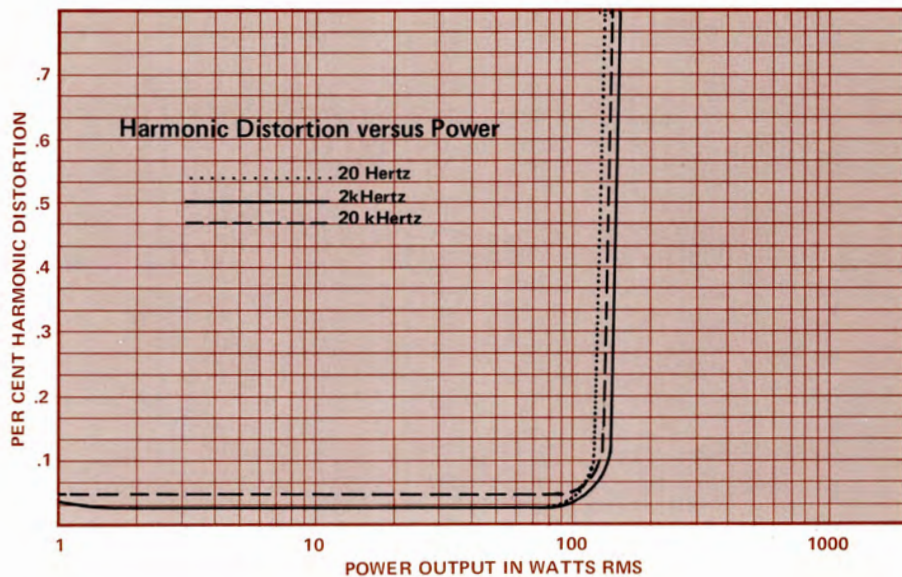

Technical Description

A two stage preamplifier with three transistors increases the input voltage 16 db.

There are 13 transistors in the power amplifier section. The two stage preamplifier is fed to a pair of matched transistors arranged as an emitter coupled amplifier with two inputs and one output. The signal from the preamplifier section connects to one of these inputs. Both AC and DC negative feedback are applied to the other input. This large quantity of feedback is used to reduce noise and distortion. The signal is then fed to a voltage amplifier. The voltage amplifier is followed by two driver transistors.

The output section is arranged as a series push-pull amplifier. The power transistors used in the output section of your MC 100 are selected for their high power dissipation capability, wide frequency response, and large "safe operating area." In addition, each power transistor is given four separate tests before it is put in your MC 100. This additional testing makes sure your MC 100 will deliver its rated power from 20 Hz to 20,000 Hz with low distortion and complete reliability.

The power transistors are mounted on oversized anodized heat sinks. The heat sinks assure that under normal operation the transistors will operate at a low temperature. If temperatures increase due to a shorted speaker, or restricted ventilation, an automatic temperature sensing device turns off the power to the MC 100. The device operates automatically at a preset temperature. The MC 100 will turn on again when the temperature has returned to normal limits. This additional feature gives your MC 100 complete reliability under the most extreme operating conditions.

The output stages are matched to the load by the McIntosh autoformer. The McIntosh autoformer is carefully wound using McIntosh trifilar winding and interleaving techniques. Trifilar winding and interleaving gives the autoformers exceptional bandwidth. The autoformers properly match the power transistors to 4, 8, and 16 ohm loads at all audio frequencies.

The use of the McIntosh designed trifilar autoformer makes the McIntosh solid state amplifiers the only amplifiers that deliver FULL POWER AT ALL SPEAKER IMPEDANCES. You have not been power penalized for your choice of loudspeakers when using the McIntosh MC 100.

Another of the advantages of the autoformers is the 25 volt output for a constant voltage distribution system. With the MC 100 several sets of speakers can be operated independently throughout your home.

To further insure reliability a special power output SENTRY MONITORING CIRCUIT prevents failure of the power output transistors due to excessive mismatch of the output. When your MC 100 operates normally the SENTRY MONITORING CIRCUIT has no effect on signals passing through the power amplifier. If the power dissipation should rise above normal operation, the SENTRY MONITORING CIRCUIT restricts the drive to the output transistors. The SENTRY MONITORING CIRCUIT acts instantaneously for any input signal or load combination. This arrangement assures complete circuit reliability. Only McIntosh gives you this degree of protection.

There are three separate power supply sections. One positive and one negative high current supply is used for the output stages. The other positive supply is used for the driving amplifier stages. All supplies are full wave and use silicon rectifiers. Adequate filtering is used to assure an absolute minimum of hum. The power output stage filter capacitors have very high capacity, which allows full power output below 20 Hz. The power transformer is generous in size and runs cool, even under heavy use.

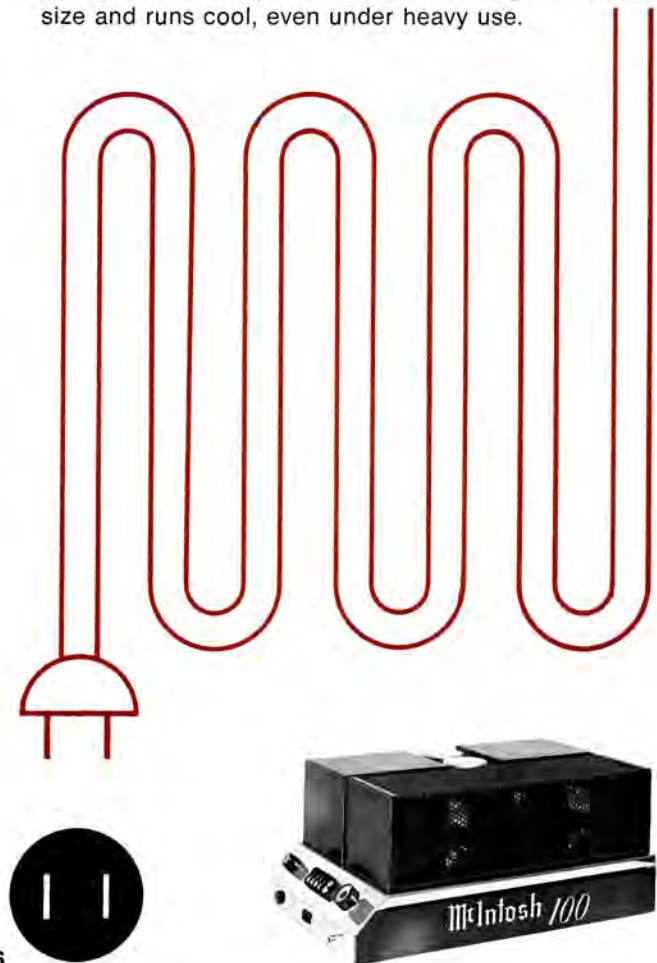

Block Diagram

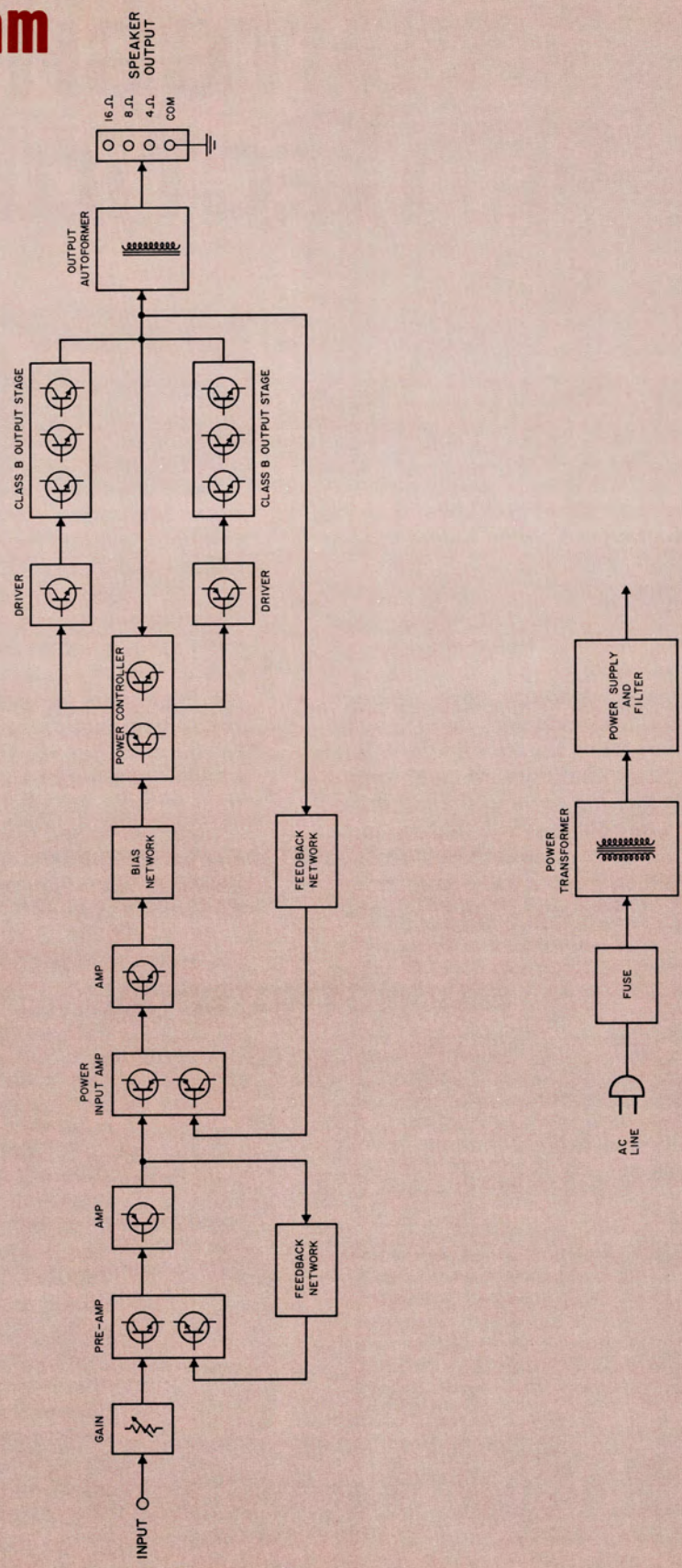

McINTOSH PROTECTION

FIRST PROTECTION....

In these dark days of hurry up—percentage analysis—production rush—and *limited personal responsibility* the McIntosh policy of "Performance Limits" is a bit of bright blue sky. Every McIntosh instrument—every one—is tested to be equal to or better than the performance limits advertised. When a performance limit of 0.20% harmonic distortion is established for an instrument, McIntosh means that every, each, all of the instruments manufactured must be capable of performance to that limit—or better—or your full purchase price is refunded.

One of the reasons McIntosh can make this promise is: we 100% test every product for maximum performance. We are not content knowing that 10% of our products are tested and meet the performance requirements established by our engineering group. We must know that every one meets its requirements. This vigorous pursuit of excellence takes time. At McIntosh more time means more care, more protection for you. There's no production rush at McIntosh.

The McIntosh investment in professional testing instruments is staggering. On a percentage basis McIntosh probably invests more of its sales dollars in testing facilities than anyone else in a like business. For instance, McIntosh has one professional distortion analyzer for every 10 employees. This kind of statistic is repeated for all sorts of test instruments. As new testing instruments are produced that update the McIntosh ability to know, McIntosh invests in them—wave form analyzers—real time analyzers—lowest distortion signal generators—etc., etc. Even so far as a small FM transmitter so that the entire transmission/reception system can be analyzed.

"What does this mean to me?" you ask. Only through this impressive investment; through continuous testing and research; through product analysis; and endless measurement can we promise and deliver to you *reliability, long life, performance, highest value, and freedom from service.*

SECOND PROTECTION....



McIntosh Laboratory has great belief in its engineering, product development, manufacturing and quality control. To offer you strong evidence of this confidence McIntosh offers you a **FREE THREE YEAR SERVICE CONTRACT.** During the first three years you can't spend one dime for service. McIntosh guarantees labor. It costs you nothing. The extended life of a McIntosh, the conservative ratings, and the sophisticated appearance make a McIntosh instrument a greater value when you are ready to trade.

McIntosh

McINTOSH LABORATORY INC.

2 CHAMBERS ST., BINGHAMTON, N. Y. 13903

607-723-3512

Design subject to change without notice.

Printed in U.S.A.

038-366